



TA PEAK

CATALOGUE
Softstarter

MCR8 series

Online intelligent motor soft starter/cabinet

Operating Instructions



Chapter 1 Cautionary Statement	01
1.1 Risk of electric shock	01
1.2 Disposal instructions	03
Chapter 2 Introduction	04
2.1 Function list	04
Chapter 3 Conditions of Use and Installation Requirements	05
3.1 Operating conditions of the online intelligent motor soft starter/cabinet	05
3.2 The appearance and installation dimensions of the online intelligent motor soft starter	06
3.3 The appearance and installation dimensions of the online intelligent motor soft starter cabinet	07
Chapter 4 Description of External Terminals of Online Smart Motor Soft Starter/Cabinet	08
Chapter 5 Motor Connection	10
Chapter 6 Operation Panel	11
Chapter 7 Basic Parameters	12
Chapter 8 Troubleshooting	15
8.1 Protection response	15
8.2 Trip message	15
Chapter 9 Function Description	17
Chapter 10 Appendix	18

Chapter 1 Cautionary Statement



This symbol is used in this manual to remind readers to attach great importance to special precautions concerning equipment installation and operation.

The caution statement cannot cover every possible cause of equipment damage, but it can emphasize common causes of damage. The installer must read and understand all the instructions in this manual before installing, operating or maintaining the equipment, and must follow effective electrical installation practices (including wearing appropriate personal protective equipment), such as using a method different from that described in this manual. To operate the equipment, advice must be sought in advance.

Notice



The user cannot repair the soft start. The soft start can only be serviced by authorized service personnel. Unauthorized modification of the soft starter will invalidate the product warranty.

1.1 Risk of electric shock

There are voltages in the following locations, which may cause serious electric shock accidents and may be fatal:

- AC power cord and connection
- Output wires and connections
- Many parts of starter and external optional equipment

Before opening the starter cover or performing any maintenance work, the AC power supply must be isolated from the starter with an approved isolating device.



Warning-risk of electric shock

As long as the supply voltage is connected (including when the starter is tripped or waiting for a command), the bus and the heat sink must be considered live.



Short circuit

Cannot prevent short circuit. After a severe overload or short circuit occurs, an authorized service agent should fully test the soft start working conditions.



Grounding and branch circuit protection

The user or installer must provide proper grounding and branch circuit protection in accordance with the requirements of local electrical safety regulations.



For safety

- The stop function of the soft start does not isolate the dangerous voltage at the output of the starter. Before touching the electrical connection, the soft starter must be disconnected with an approved electrical isolation device.
- The soft start protection function is only applicable to motor protection. The user must ensure the safety of machine operators.
- In some installation situations, accidental starting of the machine may endanger the safety of machine operators and may damage the machine. In such cases, it is recommended that you install an isolating switch and circuit breaker (such as a power contractor) that can be controlled by an external safety system (such as emergency stop and fault detection period) on the soft starter power supply.
- The soft starter has a built-in protection mechanism, and the starter trips when a fault occurs to stop the motor. Voltage fluctuations, power outages and motor jams can also cause the motor to trip.
- After eliminating the cause of the shutdown, the motor may restart, which may endanger the safety of some machines or equipment. In this case, proper configuration must be made to prevent the motor from restarting after an unexpected shutdown.
- The soft start is a well-designed component that can be integrated into the electrical system; the system designer/user must ensure that the electrical system is safe and meets the requirements of the corresponding local safety standards.
- If you do not comply with the above recommendations, our company will not bear any responsibility for any damage caused thereby.

1.2 Disposal instructions



Equipment with electrical parts cannot be treated as domestic waste.

Electrical and electronic waste must be collected separately in accordance with current local laws.

Our company keeps improving products and reserves the right to modify or change product specifications at any time without notice.

The text, diagrams, pictures and any other textual or artistic works in this manual are protected by copyright law. Users can copy some of the materials for personal reference. Without the prior permission of our company, they are not allowed to copy the materials for any other purpose.

Our company tries its best to ensure that the information (including pictures) in this manual is accurate, but does not assume any responsibility for errors, omissions or inconsistencies in the book.

Chapter 2 Introduction

This soft starter is an advanced digital soft start solution, suitable for motors with power from 5.5kW to 320kW. Provides a complete set of motor and system protection functions to ensure reliable performance even in the harshest installation environment.

2.1 Function list

Optional soft start curve

- Voltage ramp start
- Current limit start
- Torque start

Optional soft stop curve

- Free parking
- Timed soft parking

Expanded input and output options

- Remote control input
- Relay output
- Analog output
- RS485 communication output

Easy-to-read display shows comprehensive feedback

- Removable operation panel
- Built-in Chinese + English display

Customizable protection

- Input phase loss
- Output phase loss
- Soft start overheating
- Phase sequence
- Running overload
- Starting overcurrent
- Running overcurrent
- Overpressure
- Undervoltage
- Underload

Models that meet all connection requirements

- 11A-800A (rated)
- 220VAC-380VAC
- Star connection or inner delta connection

Chapter 3 Conditions of Use and Installation Requirements

The on-line intelligent motor soft starter should meet the following conditions of use and installation method requirements; otherwise, the performance will not be guaranteed, and in severe cases, the on-line motor soft starter life may be shortened or even damaged.

3.1 The use conditions of online intelligent motor soft start:

- Power supply: mains, self-supplied power station, diesel generator set, three-phase AC 220V, 380V, 30Hz to 70Hz, the power supply capacity must meet the starting requirements of the soft starter for the motor.
- Applicable motor: squirrel-cage three-phase asynchronous motor. The rated power of the motor should match the rated power of the on-line intelligent motor soft starter.
- Starting frequency: No requirement, the specific number depends on the load.
- Cooling method: forced air cooling.
- Degree of protection: IP20.
- Environmental conditions: below 2000 meters above sea level, ambient temperature between $-10^{\circ}\text{C}\sim+40^{\circ}\text{C}$, relative humidity below 95%RH, no condensation, no flammable, explosive, corrosive gas, no conductive dust, indoor ventilation Good places where the vibration is less than 0.5G. Above 2000 meters above sea level, derating is required.
- The company can provide users with products that are used under special conditions, such as explosion-proof, low-temperature, and high-voltage on-line intelligent motor soft start. The conditions of use will be explained separately.

3.2 The appearance and installation dimensions of the online intelligent motor soft starter:

Voltage Level	Rated Working Current	Rated Power	Display Method	Parameter Number	Protect Type	Input Output Number Of Terminals	Overload Capacity
220V	11A-800A	5.5kW-220kW	Chinese English LCD	49	10	11	Adjustable
380V	11A-800A	5.5kW-400kW					

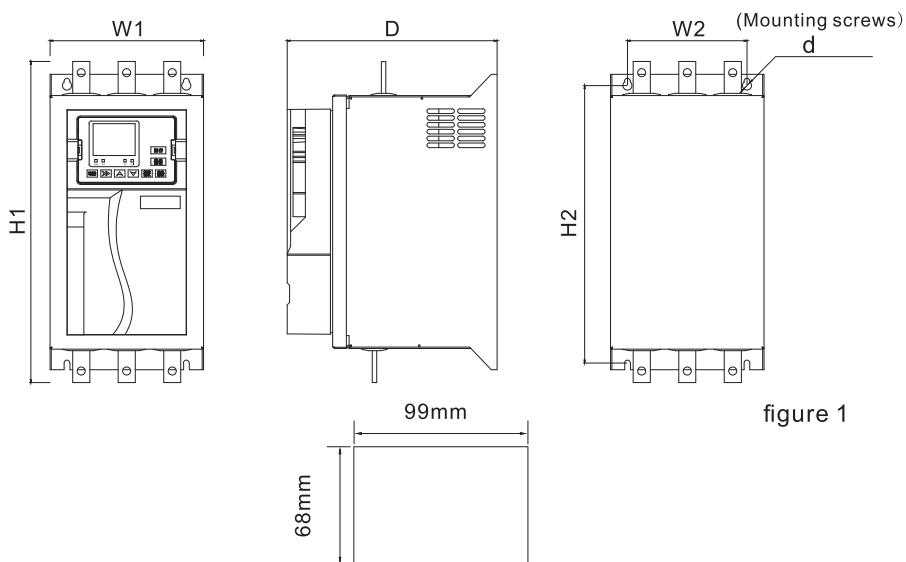

figure 1

External keyboard installation size (mm)

Specification model	Dimensions (mm)			Installation size (mm)			Outline
	W1	H1	D	W2	H2	d	
11A-75A	105	240	168.5	75	211	M6	Figure 1
90A-150A	135	282.5	184.5	105	244	M6	
180A-230A	190	370.5	224.5	150	322	M8	
264A-400A	225	393	226	170	340	M8	
440A-700A	483	586	296	340	498	M8	
800A	483	637.5	296	340	548	M8	

Online intelligent motor soft starter/cabinet

3.2 The appearance and installation dimensions of the online intelligent motor soft starter cabinet:

Voltage Level	Rated Working Current	Rated Power	Display Method	Parameter Number	Protect Type	Input Output Number Of Terminals	Overload Capacity
220V	11A-800A	5.5kW-220kW	Chinese English LCD	49	10	11	Adjustable
380V	11A-800A	5.5kW-400kW					

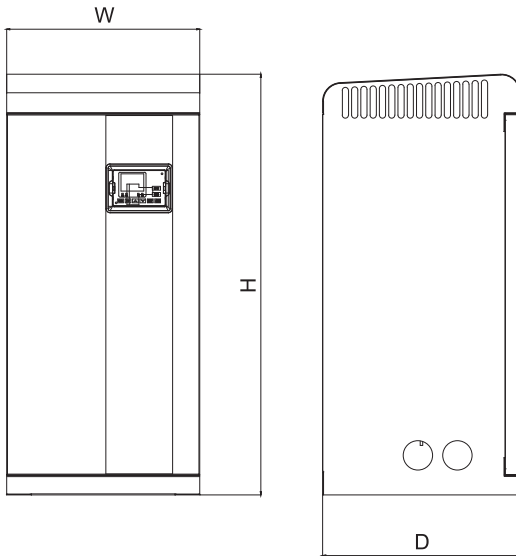
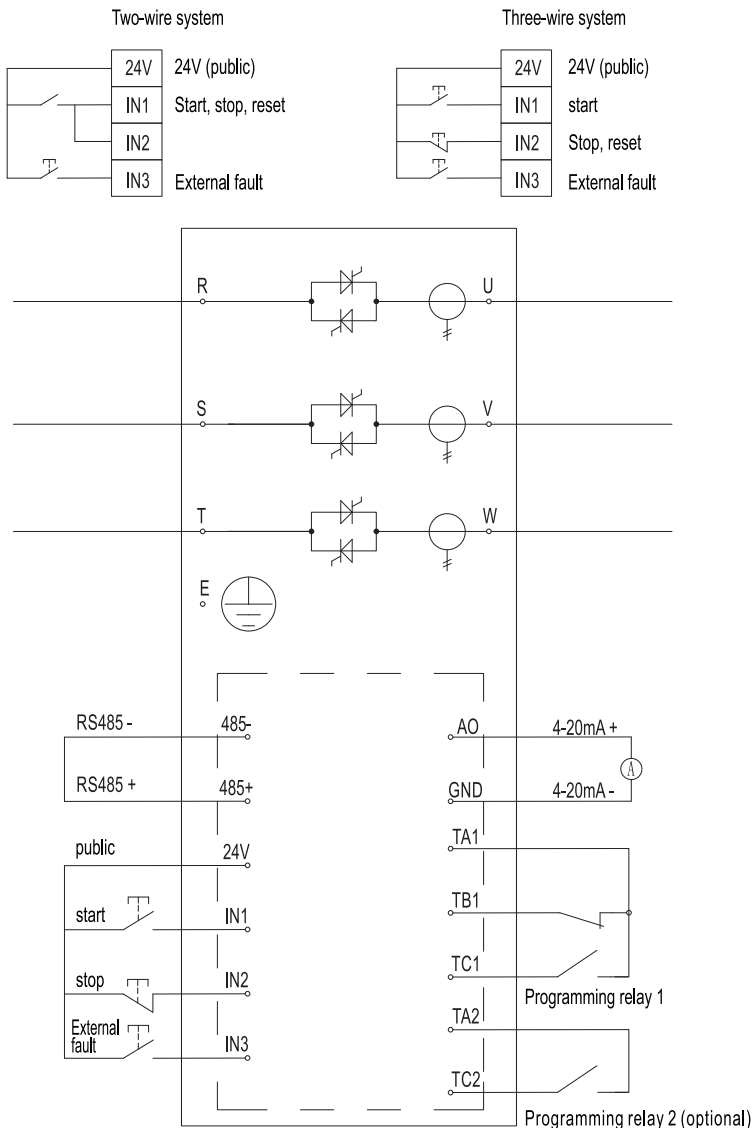

figure 2

Specification model	Dimensions (mm)			Outline
	W	H	D	
11A-150A	312	681	320	figure 2
180A-230A	350	950	400	
264A-400A	400	1130	400	
440A-800A	600	1350	470	

Chapter 4 Description of External Terminals of Online Smart Motor Soft Starter



Terminal type	Terminal No.	Terminal name	Instruction	
Main circuit	R,S,T	Power Input	Soft start three-phase AC power input	
	U,V,W	Soft Start Output	Connect three-phase asynchronous motor	
Control loop	Communication	485-	RS485-	For ModBusRTU communication
		485+	RS485+	
	Digital input	24V	Public	24V common
		IN1	Start	Short connection with common terminal (24V) Startable soft start
		IN2	Stop	Disconnect from the common terminal (24V) to stop the start soft start
		IN3	External Fault	Short-circuit with the common terminal (24V), soft start and shutdown
	Analog output	AO	4-20ma Output Positive	4-20mA output
		GND	4-20ma Output Negative	
	Programming Relay 1	TA1	Programming relay common	Programmable output, available from Choose from the following functions: 0. No action 1. Power-on action 2. Soft start action 3. Bypass action 4. Soft stop action 5. Runtime actions 6. Standby action 7. Failure action
		TB1	Programming relay normally closed	
		TC1	Programming relay normally open	
Programming Relay 2 (optional)		TA2	Programming relay normally open	
	TC2			

Chapter 5 Motor Connection

Soft start can use star connection method or inner delta connection method (also called three-wire connection method and six-wire connection method) to connect the motor. If the inner delta connection method is adopted, use parameter F02 to input the rated current of the motor.

Star connection

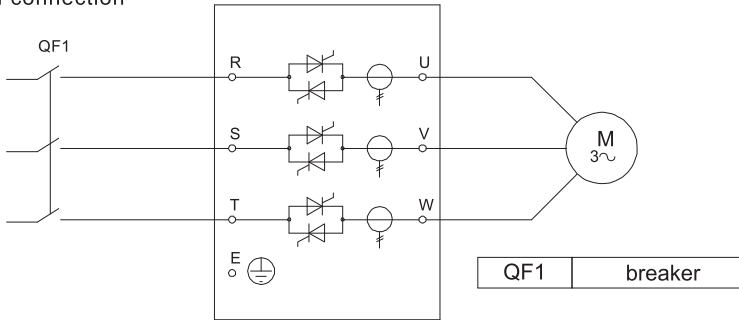

Inner triangle connection method

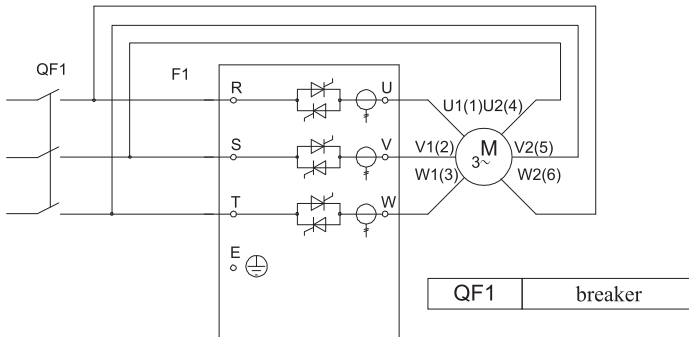





Notice

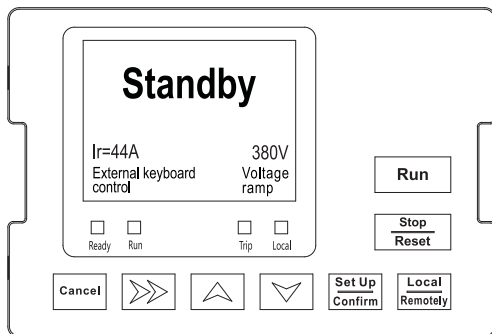

If the inner delta connection method is adopted, use parameter F02 to input the rated current of the motor. Whether the soft starter adopts the star connection method or the inner delta connection method is modified by the parameter "F18 motor connection method".

Chapter 6 Operation Panel



Button	Name	Function
Cancel	Cancel key	1. Exit the parameters. 2. Cancel modification parameters
	Shift key	1. Shift key when modifying parameters. 2. View the fault record in the main interface.
	Increment key	Increment of data and parameter codes.
	Decrement key	Decrement of data and parameter codes.
Run	Run key	In keyboard operation mode, it is used for running operation.
Stop/reset	Stop/reset button	In the running state, press this key to stop the operation; It can be used to reset operation when it is in a fault state.
Set/confirm	Set/Confirm key	1. Enter the parameter menu. 2. Set the parameters to confirm.
Local/remotely	Panel control keys	Turn keyboard control on or off.

Starter status LED

Name	Chang Liang	Flashing
Ready	The motor stops and the starter is ready to start.	
Run	The motor is in the state of starting, running, soft stop, and DC braking.	
Trip	The starter has tripped.	The starter is in a warning state.
Local	The starter is in local control mode.	-

- The local LED light only works for the keyboard control mode. The light on means that the panel can be started and stopped, and the light off means that the panel cannot be started or stopped.

Chapter 7 Basic Parameters

No.	No.	Function Name	Setting Range	Defaults
0	F00	Soft start rated current		
1	F01	Soft start rated voltage		
2	F02	Motor rated current		
3	F03	Way to control	0: Prohibit start and stop 1: The keyboard is individually controlled 2: External control alone control 3: Keyboard + external control 4: Communication is controlled separately 5: keyboard + communication 6: External control+communication 7: keyboard + external control + communication	3: Keyboard + external control
4	F04	Starting method	0: Voltage ramp start 1: Current limit start 2: Torque start	0: Voltage ramp start
5	F05	Starting current limit percentage	50%~600%	300%
6	F06	Percentage of starting voltage	30%~80%	35%
7	F07	Starting time	1s~120s	15s
8	F08	Sustain voltage	60%~85%	65%
9	F09	Early acceleration time	1s~10s	5s
10	F10	Hold time	1s~120s	10s
11	F11	After acceleration time	1s~10s	3s
12	F12	Soft stop time	0s~60s	0s
13	F13	Programmable relay 1	0: No action 1: Power-on action 2: Soft start action 3: Bypass action 4: Soft stop action 5: Run action 6: Standby action 7: Failure action	7: Failure action
14	F14	Relay 1 delay	0~600s	0s
15	F15	Programming relay 2 (optional)	0: No action 1: Power-on action 2: Soft start action 3: Bypass action 4: Soft stop action 5: Run action 6: Standby action 7: Failure action	3: Bypass action
16	F16	Relay 2 delay	0~600s	0s
17	F17	4-20mA upper limit current	50%~500%	200%
18	F18	Motor wiring method	0: Line type 1: Inner triangle	0: Line type

Online intelligent motor soft starter/cabinet

No.	No.	Function Name	Setting Range	Defaults
19	F19	Mailing Address	1~127	1
20	F20	Communication baud rate	0:2400 1:4800 2:9600 3:19200	2:9600
21	F21	Operation overload level	1~30	10
22	F22	Starting overcurrent multiple	50%-600%	500%
23	F23	Start over current protection time	0s-120s	5s
24	F24	Operating overcurrent multiple	50%-600%	200%
25	F25	Running overcurrent protection time	0s-6000s	5s
26	F26	Overvoltage protection multiple	100%~140%	120%
27	F27	Overvoltage protection time	0s~120s	5s
28	F28	Undervoltage protection multiple	50%-100%	80%
29	F29	Undervoltage protection time	0s~120s	5s
30	F30	Three-phase unbalance	20%~100%	40%
31	F31	Three-phase unbalance protection time	0s~120s	10s
32	F32	Underload protection multiple	10%~100%	50%
33	F33	Underload protection time	1s~120s	10s
34	F34	Soft phase sequence	0: Any phase sequence 1: Forward sequence 2: Reverse order	0: Any phase sequence
35	F35	A phase current calibration value	10%~1000%	100%
36	F36	B Phase current calibration value	10%~1000%	100%
37	F37	C phase current calibration value	10%~1000%	100%
38	F38	Voltage calibration value	10%~1000%	100%
39	F39	4-20mA lower limit calibration	0%~150.0%	20.0%
40	F40	4-20mA upper limit calibration	0%~150.0%	100.0%
41	F41	Running overload protection	0: Trip and shutdown 1: neglect	0: Trip and shutdown
42	F42	Start overcurrent protection	0: Trip and shutdown 1: neglect	0: Trip and shutdown
43	F43	Running overcurrent protection	0: Trip and shutdown 1: neglect	0: Trip and shutdown
44	F44	Overvoltage protection	0: Trip and shutdown 1: neglect	0: Trip and shutdown
45	F45	Undervoltage protection	0: Trip and shutdown 1: neglect	0: Trip and shutdown

No.	No.	Function Name	Setting Range	Defaults
46	F46	Three-phase unbalance protection	0: Trip and shutdown 1: neglect	0: Trip and shutdown
47	F47	Underload protection	0: Trip and shutdown 1: neglect	0: Trip and shutdown
48	F48	Overheating protection	0: Trip and shutdown 1: neglect	0: Trip and shutdown
49	F49	Output phase loss protection	0: Trip and shutdown 1: neglect	0: Trip and shutdown
50	F50	Soft start language	0: English 1: Chinese	1: Chinese
51	F51	Water pump matching selection	0: None 1: Float 2: Electric contact pressure gauge 3: Water supply level relay 4: Drain level relay	0: without
52	F52	Soft start type selection	0: Online 1: Bypass type	0: Online
53	F53	Main control software version		
54	F54	Show software version		

Water pump matching function selection

Water Pump Matching Function Selection		
①	0: None	None: Standard soft start function.
②	1: Float	Float: IN1, start when closed, stop when open. IN2 has no function.
③	2: Electric contact pressure gauge	Electric contact pressure gauge: When IN1 is closed, it starts, and when IN2 is closed, it stops.
④	3: Water supply level relay	Water supply level relay: IN1 and IN2 are both disconnected and started, IN1 and IN2 are both closed and stopped.
⑤	4: Drain level relay	Drainage level relay: IN1 and IN2 are disconnected and stopped, IN1 and IN2 are both closed and started.

Note: The water supply function starts and stops controlled by IN3, the standard soft start IN3 is an external fault, and the water supply type is used to control the start and stop, IN3 is the starting end, and the above operation can be performed only when it is closed, and it stops when it is open.

0: None

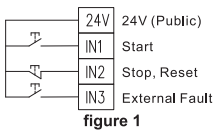

1: Float

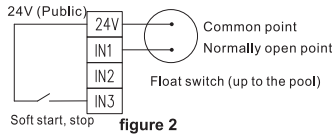

2: Electric contact pressure gauge

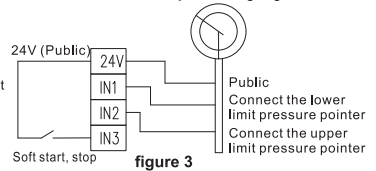

3: Water supply level relay

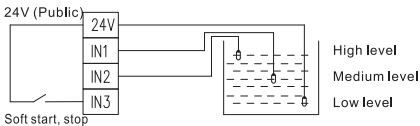

4: Drain level relay

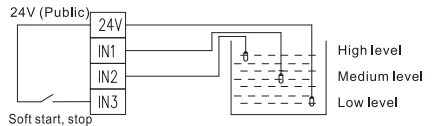

Chapter 8 Troubleshooting

8.1 Protection response

When the protection condition is detected, the soft starter writes the protection condition into the program, and it may trip or issue a warning. The soft start response depends on the protection level.

The user cannot adjust some of these protection responses. These trips are usually caused by external events (such as phase loss), and may also be caused by internal faults in the soft start. These trips have no relevant parameters and cannot be set as warning or ignored.

If the soft start trips, you need to identify and clear the conditions that triggered the trip, reset the soft start, and then restart. To reset the starter, press the (stop/reset) button on the operation panel, or activate "Stop/reset remote input".

8.2 Trip message

The following table lists the protection mechanism of soft start and possible trip reasons. Some settings can be adjusted with the protection level, while other settings are built-in system protection and cannot be set or adjusted.

No.	Fault name	Possible Causes	Suggested solution	Remark
01	Input phase loss	<ol style="list-style-type: none"> 1. The start command is issued, and one or more phases of the soft start are not energized. 2. The main board of the circuit board is faulty. 	<ol style="list-style-type: none"> 1. Check whether the main circuit has electricity 2. Check whether the SCR of the input circuit is open, and whether the pulse signal line is in poor contact. 3. Seek help from the manufacturer. 	This trip is not adjustable
02	Output phase loss	<ol style="list-style-type: none"> 1. Whether the SCR is short-circuited. 2. One or more phases of the motor wire are open. 3. The main board of the circuit board is faulty. 	<ol style="list-style-type: none"> 1. Check whether the SCR is short-circuited. 2. Check whether the motor wire is open. 3. Seek help from the manufacturer. 	Related parameters: F49
03	Running overload	<ol style="list-style-type: none"> 1. The load is too heavy. 2. Improper parameter settings. 	<ol style="list-style-type: none"> 1. Replace the soft starter with more power. 2. Adjust the parameters. 	Related parameters: F21, F41

Online intelligent motor soft starter/cabinet

No.	Fault name	Possible Causes	Suggested solution	Remark
04	Underload	1. The load is too small. 2. Improper parameter settings.	1. Adjust the parameters.	Related parameters: F32, F33 F47
05	Soft overheating	1. The temperature switch is faulty. 2. The fan does not rotate. 3. The working time of soft start is too long.	1. Check whether the temperature switch is faulty. 2. Check whether the fan is working normally. 3. Stop the machine and let the soft start cool down.	Related parameters: F48
06	Over-pressure	1. The input power supply voltage is too high. 2. Improper parameter settings.	1. Check the power supply voltage. 2. Adjust the parameters.	Related parameters: F26, F27, F44
07	Under-voltage	1. The input power supply voltage is too low. 2. Improper parameter settings.	1. Check the power supply voltage. 2. Adjust the parameters.	Related parameters: F28, F29, F45
08	Running overcurrent	1. The load is too heavy. 2. Improper parameter settings.	1. Replace the soft starter with more power. 2. Adjust the parameters.	Related parameters: F24, F25, F43
09	Starting overcurrent	1. The load is too heavy. 2. Improper parameter settings.	1. Replace the soft starter with more power. 2. Adjust the parameters.	Related parameters: F22, F23, F42
10	External fault	1. The external fault terminal has input.	1. Check whether there is input at the external terminal.	Related parameters: without
11	Phase sequence failure	1. The input power phase sequence is inconsistent with the setting.	1. Adjust the power phase sequence. 2. Adjust the parameters.	Related parameters: F34
12	Current imbalance	1. The power supply voltage is unbalanced. 2. There is a problem with the motor winding. 3. There is a problem with the transformer.	1. Check the power supply voltage. 2. Check the motor winding. 3. Check whether the transformer is open circuit.	Related parameters: F30, F31, F46

Chapter 9 Function Description

Overload protection

Overload protection adopts inverse time limit control

$$\text{Guard time: } t = \frac{35 \cdot T_p}{(I/I_p)^2 - 1}$$

Among them: t represents the operating time, T_p represents the protection level, I represents the operating current, I_p represents the motor rated current

Motor overload protection characteristic curve: Figure 11-1

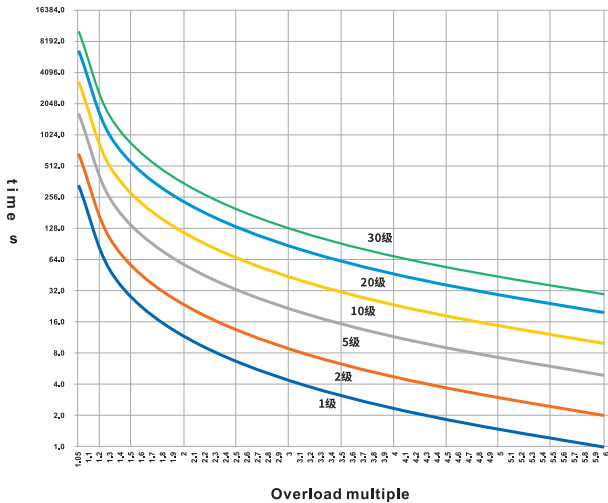

Motor overload protection characteristics

overload level \ overload multiple	1.05Ie	1.2Ie	1.5Ie	2Ie	3Ie	4Ie	5Ie	6Ie
1	∞	79.5s	28s	11.7s	4.4s	2.3s	1.5s	1s
2	∞	159s	56s	23.3s	8.8s	4.7s	2.9s	2s
5	∞	398s	140s	58.3s	22s	11.7s	7.3s	5s
10	∞	795.5s	280s	117s	43.8s	23.3s	14.6s	10s
20	∞	1591s	560s	233s	87.5s	46.7s	29.2s	20s
30	∞	2386s	840s	350s	131s	70s	43.8s	30s

∞: Indicates no action

Chapter 10 Appendix

Model code

